

**Regulations and General Advice of the Swedish
Maritime Administration on Swedish Ice Class
for traffic on Lake Vänern**

SJÖFS 2003:16

decided on November 13, 2003.

Appeared from print
on December 1, 2003

The Swedish Maritime Administration provides¹ as follows, pursuant to section 4 of chapter 2 of the Ship Safety Ordinance (2003:438) and section 5 of the Ice Breaker Ordinance (2000:1149) and decides on the following general advice.

Chapter 1 Application

1 § These regulations are applicable to traffic on Lake Vänern for ships, the keel of which have been laid down or building has started on January 1, 2004 or later, and which are entitled to assistance according to the Ice Breaker Ordinance (2000:1149).

Ships to which these regulations are applicable and which do not have ice class in accordance with the regulations of the Swedish Maritime Administration (2003:4) and general advice on Finnish-Swedish ice class shall have one of the following ice classes:

- Ice Class IBV
- Ice Class ICV.

2 § If a ship because of unconventional proportions, hull shape, propulsion arrangements, or any other characteristics in practice should turn out to have exceptionally poor ice-going capability the Swedish Maritime Administration may lower its ice class.

3 § When designing structures, equipment and arrangements which are important for the safety and operation of the ship, the influence of ambient temperature shall be considered.

General Advice

Factors to be considered are e.g. the functioning of hydraulic systems, risk of freezing of water piping and tanks, starting of emergency diesels, low temperature strength of materials etc. The air temperature may be well below 0°C for long periods and might occasionally fall to about -30°C.

4 § Ships approved in accordance with legislation of other member states in the European Union and the European Economic Area are ranked in the same category as ships which fulfil the requirements of these regulations, provided that an equal safety level is achieved by such legislation.

5 § In addition to the requirements of these regulations ships shall fulfil the requirements stated in chapters 4-7 of the Regulations of the Swedish Maritime Administration (SJÖFS 2003:4) and General Advice on Finnish-Swedish Ice Class.

¹ In accordance with Directive 98/34/EG of the European Parliament and the Council of June 22, 1998 notification has been made regarding a procedure for the provision of information in the field of technical standards and regulations and rules on Information Society services (EGT L 204, 21.7.1998, p.37, Celex 398L0034) amended in directive of the European Parliament and the Council 98/48/EG (EGT L 217, 5.8.1998, s. 18, Celex 398L0048).

Chapter 2 Ice Class Draught

Maximum draught amidships

1 § The maximum ice class draught amidships shall in general be the draught on the summer Fresh Water Load Line. If the ship has a timber load line, the summer Fresh Water Timber Load Line shall be used.

Maximum and minimum draught fore and aft

2 § The maximum and minimum ice class draughts fore and aft shall be decided and stated in the classification certificate.

3 § The line defined by the maximum draughts fore, amidships and aft will henceforth be referred to as LWL. This may be a broken line. The line defined by the minimum draughts fore and aft will be referred to as BWL.

4 § The draught and trim, limited by the LWL, must not be exceeded when the ship is navigating in ice. The salinity of the seawater along the intended route shall be taken into account when loading the ship.

5 § The ship shall always be loaded at least to the BWL when navigating in ice. Any ballast tank located above the BWL and which is needed to load the ship down to this water line, shall be equipped with devices to prevent the water from freezing.

6 § When determining the BWL, the need for ensuring a reasonable degree of ice-going capability in ballast shall be considered. The propeller shall be fully submerged, if possible entirely below the ice.

7 § The forward draught shall be at least:

$(2 + 0,00025 \Delta) h_0$ [m], but need not exceed $4 h_0$ where

Δ = displacement of the ship [t] on the maximum ice class draught according to Chap 2 section 1.

h_0 = ice thickness, 0.6 m for Ice Class IBV
0.4 m for Ice Class ICV

Chapter 3 Engine Output

1 § The engine output P is the maximum output which the propulsion machinery continuously can deliver to the propeller(s). If the output of the machinery is restricted by technical means or by any regulations applicable to the ship, P shall be taken as the restricted output.

Required engine output for Ice Classes IBV and ICV

2 § The engine output shall be calculated at the draughts which correspond to LWL and BWL respectively. The engine output shall not be less than any of these as per the formula below and in no case less than 1000 kW.

3 § The parameters of the ship defined below are measured on the draughts corresponding to LWL and BWL respectively.

L = length of the ship between perpendiculars [m]

L_{BOW} = length of the bow [m], only used for defining A_{wf}

L_{PAR} = length of the parallel amidship body [m]

B = maximum breadth of the ship [m]

T = maximum ice class draught LWL or ballast draught BWL [m] according to Chap 2 section 3.

A_{wf} = waterplane area of the bow [m²]

α = the angle of the waterline at B/4 [degrees]

φ_2 = the angle of the buttock at B/4 [degrees]

D_p = diameter of the propeller [m]

H_M = thickness of the brash ice in mid channel [m]
 H_F = thickness of the brash ice layer displaced by the bow [m]

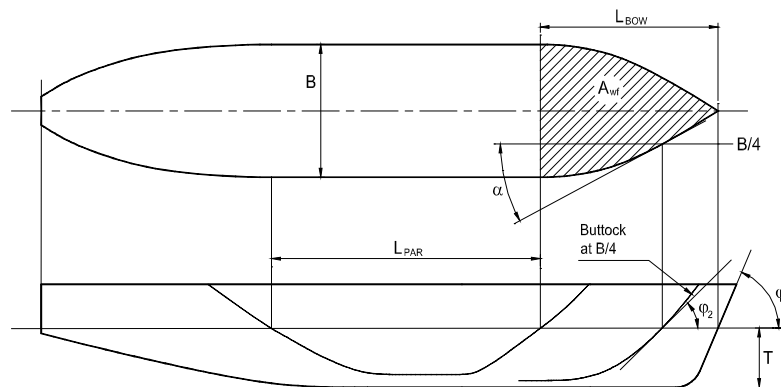

Figure 1

When determining the ship's parameters, which depend on the draught, the prevailing draughts shall be used. T in the parameter D_p/T refers to LWL. L and B are always determined at the maximum ice class draught LWL.

Range of validity

4 § The formula for ice resistance in Chap 3 sections 5-6 shall be used when the ship's parameters are within minimum and maximum values in Table 1.

Table 1

Parameter		Minimum	Maximum
α	[°]	15	55
φ_2	[°]	10	90
L	[m]	65.0	90.0
B	[m]	11.0	14.0
T	[m]	4.0	7.0
L_{BOW}/L		0.15	0.40
L_{PAR}/L		0.25	0.75
D_p/T		0.45	0.75
$A_{wf}/(L \cdot B)$		0.09	0.27

If the ship's parameter values deviate from the ranges defined in Table 1, other methods for determining R_{CH} shall be used as defined in Chap 3 section 6

General Advice

The ice resistance equations are for natural reasons semi-empirical formulae and have thus a range of validity. It is difficult exactly to determine the range of validity. Table 1 presents the range of each parameter used.

Required engine power

5 § To be entitled to Ice Class IBV or ICV, new ships shall comply with the power requirements below:

$$P = K_e \frac{(R_{CH} / 1000)^{3/2}}{D_p} [\text{kW}]; \text{ where:}$$

K_e shall be taken as follows:

Propeller type or machinery	CP or electric or hydraulic propulsion machinery	FP propeller
1 propeller	2.03	2.26
2 propellers	1.44	1.60
3 propellers	1.18	1.31

R_{CH} is the resistance in Newton of the ship in a channel with brash ice:

$$R_{CH} = C_3 C_\mu (H_F + H_M)^2 (B + C_\psi H_F) + C_4 L_{PAR} H_F^2 + C_5 \left(\frac{LT}{B^2} \right)^3 \frac{A_{wf}}{L}$$

$$C_\mu = 0.15 \cos \varphi_2 + \sin \psi \sin \alpha, \quad C_\mu \text{ shall be equal or greater than } 0.45$$

$$C_\psi = 0.047 \cdot \psi - 2.115, \quad \text{and } C_\psi = 0 \text{ if } \psi \leq 45^\circ$$

$$H_F = 0.26 + (H_M B)^{0.5}$$

$$H_M = 0.65 \text{ for ice class IBV}$$

$$= 0.50 \text{ for ice class ICV}$$

$$C_3 = 845 \text{ kg/(m}^2\text{s}^2\text{)}$$

$$C_4 = 42 \text{ kg/(m}^2\text{s}^2\text{)}$$

$$C_5 = 825 \text{ kg/s}^2$$

$$\psi = \arctan \left(\frac{\tan \varphi_2}{\sin \alpha} \right)$$

$$\left(\frac{LT}{B^2} \right)^3 \text{ is not to be less than } 5 \text{ or greater than } 20.$$

Input data for checking calculation of power requirements are found in the *Annex*.

Other methods of determining K_e or R_{CH}

6 § For an individual ship the Swedish Maritime Administration can, in lieu of the K_e or R_{CH} values defined above, approve the use of K_e or R_{CH} values based on more exact calculations, or values based on model tests. Such an approval will be given on the understanding that it can be revoked if the experience of the ship's performance in practice motivates this.

The design requirement for the ice class is a minimum speed of 5 knots in a brash ice channel with the following thickness:

$$\text{IBV} = 0.65 \text{ m}$$

$$\text{ICV} = 0.50 \text{ m}$$

This regulation comes into force four weeks after the day when the regulation, in accordance with what is printed on it, appeared in print in the statute-book of the Swedish Maritime Administration.

JOHAN FRANSON
(Sjöfartsinspektionen)

Göran Liljeström

VERIFICATION OF CALCULATED POWERING REQUIREMENTS

To make possible control calculation of powering requirements, Table 2 shows input data for a number of sample ships.

Table 2

	Sample ship No.							
	#1	#2	#3	#4	#5			
Ice class	IBV	ICV	IBV	IBV	IBV			
α [°]	35	35	35	20	30			
ϕ_2 [°]	65	65	65	30	22			
L [m]	82	82	82	82	82			
B [m]	13	13	11.5	13	13			
T [m]	4.8	4.8	4.8	4.8	4.8			
L_{BOW} [m]	13.0	13.0	13.0	13.0	13.0			
L_{PAR} [m]	53.5	53.5	53.5	53.5	53.5			
A_{wf} [m ²]	100	100	100	150	150			
D_P [m]	2.8	2.8	2.8	2.8	2.8			
Propeller qty./type	1/CP	1/CP	1/CP	1/CP	1/CP			
New ship [kW]	1578	1042	1321	960	884			