



# Swedish Maritime Administration (Sjöfartsverket)

## Implementation Guide for UN/EDIFACT MESSAGE **IFTDGN** (Dangerous Goods Notification)

Based on PROTECT 1.0  
and UN/EDIFACT D.98B

Message Version	: PROTECT 1.0
Manual Version	: PC2
Date	: 2005-04-05
Source	: Swedish Maritime Administration (Sjöfartsverket)

## Introduction

This Implementation Guide has been developed by Swedish Maritime Administration (Sjöfartsverket) to assist interested EDI partners in developing and implementing the UN/EDIFACT IFTDGN message towards SMA (Swedish Maritime Administration).

This Implementation Guide is based on the UN/EDIFACT D.98B directory and the PROTECT document "EDIFACT message implementation guide Dangerous Goods Notification Message IFTDGN of the PROTECT dangerous goods message scenario", version 1.0, dated January 1999.  
See [www.smdg.org](http://www.smdg.org)

## General

The IFTDGN message is intended for the declaration of dangerous goods by the party responsible to declare these goods (e.g. carrier's agent) to the party acting on behalf of the local authority performing the checks on conformance with the legal requirements on the control of dangerous goods (e.g. Port Authority). The message contains information relating to one conveyance/voyage of a means of transport on the dangerous goods being loaded, unloaded or transiting.

## Document maintenance

Any remarks, questions, amendments or requested alterations to this document are to be addressed to :

Swedish Maritime Administration (Sjöfartsverket)  
Headoffice  
Att: ???  
SE-601 78 Norrköping  
Sweden  
Telephone: +46 (0)11-19 10 00  
Fax: +46 (0)11-19 14 00  
Email: ???  
[www.sjofartsverket.se](http://www.sjofartsverket.se)

## STATUS INDICATORS AND USAGE INDICATORS

### Status Indicators

Status Indicators (M and C) form part of the UN/EDIFACT standard and indicate a minimum requirement to fulfill the needs of the message structure.

The Status Indicators are:-

<i>Value</i>	<i>Description</i>
M	Mandatory This entity must appear in all messages. Shown as Usage Indicator "M" in Implementation Guidelines.
C	Conditional This entity is used by agreement between the parties to the transaction.

A 'Conditional' Status Indicator may be represented by a supporting Usage Indicator which is either R, O, D or X (see below)

### Usage Indicators

Throughout this document reference is made to indicators (M, R, D, O and X) which are shown adjacent to data items in the leftmost column in the segment section and dictate for the particular message or set thereof the agreed usage of the data items or entities.

Set out below are the indicators and their respective uses:-

<i>Value</i>	<i>Description</i>
M	Mandatory Indicates that this item is mandatory in the message.
R	Required Indicates that this entity must be sent in this implementation.
D	Dependent Indicates that the use of the entity depends upon a well-defined condition or set of conditions. These conditions must be clearly specified in the relevant implementation guideline. It's typically data that is optional, but taken care of by SMA.
O	Optional Indicates that this entity is at the need or discretion of the sender of the message. SMA doesn't use this data.
X	Not Used Indicates that the entity is not to be used in this message implementation.

**Differences between the implementation of IFTDGN at SMA and PROTECT**  
(See [www.smdg.org](http://www.smdg.org) for detailed information about PROTECT scenarios.)

Segment	Composite element	Element	SMA	PROTECT	Comments
UNH	S009	0057	Not used	Required	Association code is not allowed
RFF	---	---	Required	Conditional	RefId
TDT.RFF	---	---	Required	Conditional	PortVisitId
TDT.LOC	---	---	Required	Conditional	Contact person's location code
TDT.DTM	---	---	Required	Conditional	ETD
NAD	---	---	Required	Conditional	ContactDetails
NAD.CTA	---	---	Required	Conditional	ContactDetails
NAD.CTA.COM	---	---	Required	Conditional	ContactDetails
CNI.LOC	---	---	Required	Conditional	Load/ Discharge Port
CNI.GID.DGS. SGP.LOC	---	---	Required	Conditional	LocationOnBoardContainer

# IFTDGN Dangerous Goods Notification Message

## Introduction:

The International Forwarding and Transport Dangerous Goods Notification message is a message from the party responsible to declare the dangerous goods (e.g. carrier's agent, freight forwarder) to the party acting on behalf of the local authority performing the checks on conformance with the legal requirements on the control of dangerous goods, normally Port Authority, conveying the information relating to one conveyance/voyage of a means of transport such as a vessel, train, truck or barge, on the dangerous goods being loaded, unloaded, and/or in transit. In order to make a Dangerous Goods Notification, you first have to make a Port notification (via XML or the web).

SMA	Pos.	Seg.	UN/EDIFACT			Group Repeat	Notes and Comments	
			No.	ID	Name			Req. Des.
M	0010	UNH			Message Header	M	1	
M	0020	BGM			Beginning of Message	M	1	
R	0030	DTM			Date/Time/Period	C	1	EDIFACT=9
O	0040	FTX			Free Text	C	9	
O	0050	HAN			Handling Instructions	C	1	
R	0060		Segment Group 1: RFF-DTM			C	3	PROTECT=O, SMA req RefId EDIFACT=9
M	0070	RFF			Reference	M	1	
X	0080	DTM			Date/Time/Period	C	9	
R	0090		Segment Group 2: TDT-RFF-LOC-DTM			C	1	
M	0100	TDT			Details of Transport	M	1	
R	0110	RFF			Reference	C	9	PROTECT=O, SMA req PortVisitId
R	0120	LOC			Place/Location Identification	C	10	
R	0130	DTM			Date/Time/Period	C	2	PROTECT=O, SMA req ETD
R	0140		Segment Group 3: NAD-SG4			C	6	EDIFACT=9
M	0150	NAD			Name and Address	M	1	
R	0160		Segment Group 4: CTA-COM			C	2	EDIFACT=9
M	0170	CTA			Contact Information	M	1	PROTECT=O, SMA req ContactDetails
R	0180	COM			Communication Contact	C	3	PROTECT=O, SMA req ContactDetails EDIFACT=9
O	0190		Segment Group 5: EQD-MEA			C	999	
M	0200	EQD			Equipment Details	M	1	
O	0210	MEA			Measurements	C	1	EDIFACT=9
M	0220		Segment Group 6: CNI-HAN-DTM-LOC-SG7-SG8-SG10			M	999	
M	0230	CNI			Consignment Information	M	1	
O	0240	HAN			Handling Instructions	C	1	
O	0250	DTM			Date/Time/Period	C	4	
R	0260	LOC			Place/Location Identification	C	4	PROTECT=O, SMA req Load/Discharge Port

Message IFTDGN  
Source Swedish Maritime Administration (Sjöfartsverket)  
Document ID: EDIFACT-IFTDGN-Implementation Guide-FRS.doc

O	0270		Segment Group 7: TDT-RFF	C	1	
M	0280	TDT	Details of Transport	M	1	
O	0290	RFF	Reference	C	9	
O	0300		Segment Group 8: NAD-SG9	C	2	
M	0310	NAD	Name and Address	M	1	
O	0320		Segment Group 9: CTA-COM	C	1	
M	0330	CTA	Contact Information	M	1	
O	0340	COM	Communication Contact	C	2	EDIFACT = 1
O	0350	RFF	Reference	C	1	
M	0360		Segment Group 10: GID-FTX-PCI-SG11-SG12	M	99	
M	0370	GID	Goods Item Details	M	1	
O	0380	FTX	Free Text	C	2	
O	0390	PCI	Package identification	C	1	
D	0400		Segment Group 11: SGP-MEA	C	99	And/Or SG13
M	0410	SGP	Split Goods Placement	M	1	
O	0420	MEA	Measurements	C	1	EDIFACT=9
M	0430		Segment Group 12: DGS-FTX-MEA-SG13	M	1	
M	0440	DGS	Dangerous Goods	M	1	
M	0450	FTX	Free Text	M	2	EDIFACT=9
M	0460	MEA	Measurements	M	4	EDIFACT=9
D	0470	LOC	Place/Location Identification	C	99	Non container
O	0480	RFF	Reference	C	9	
D	0490		Segment Group 13: SGP-LOC	C	99	And/Or SG11
M	0500	SGP	Split Goods Placement	M	1	
R	0510	LOC	Place/Location Identification	C	1	PROTECT=O, SMA req LocationOnBoa rdContainer EDIFACT=2
O	0520	MEA	Measurements	C	4	
M	0530	UNT	Message Trailer	M	1	

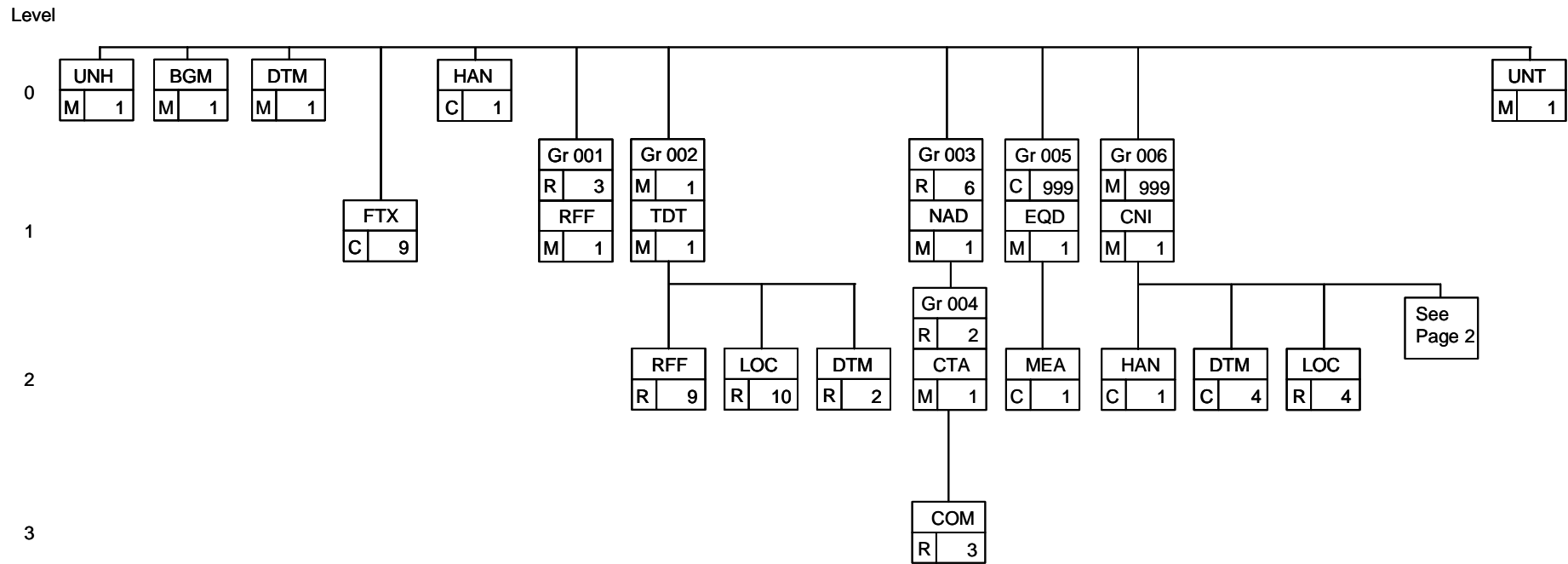

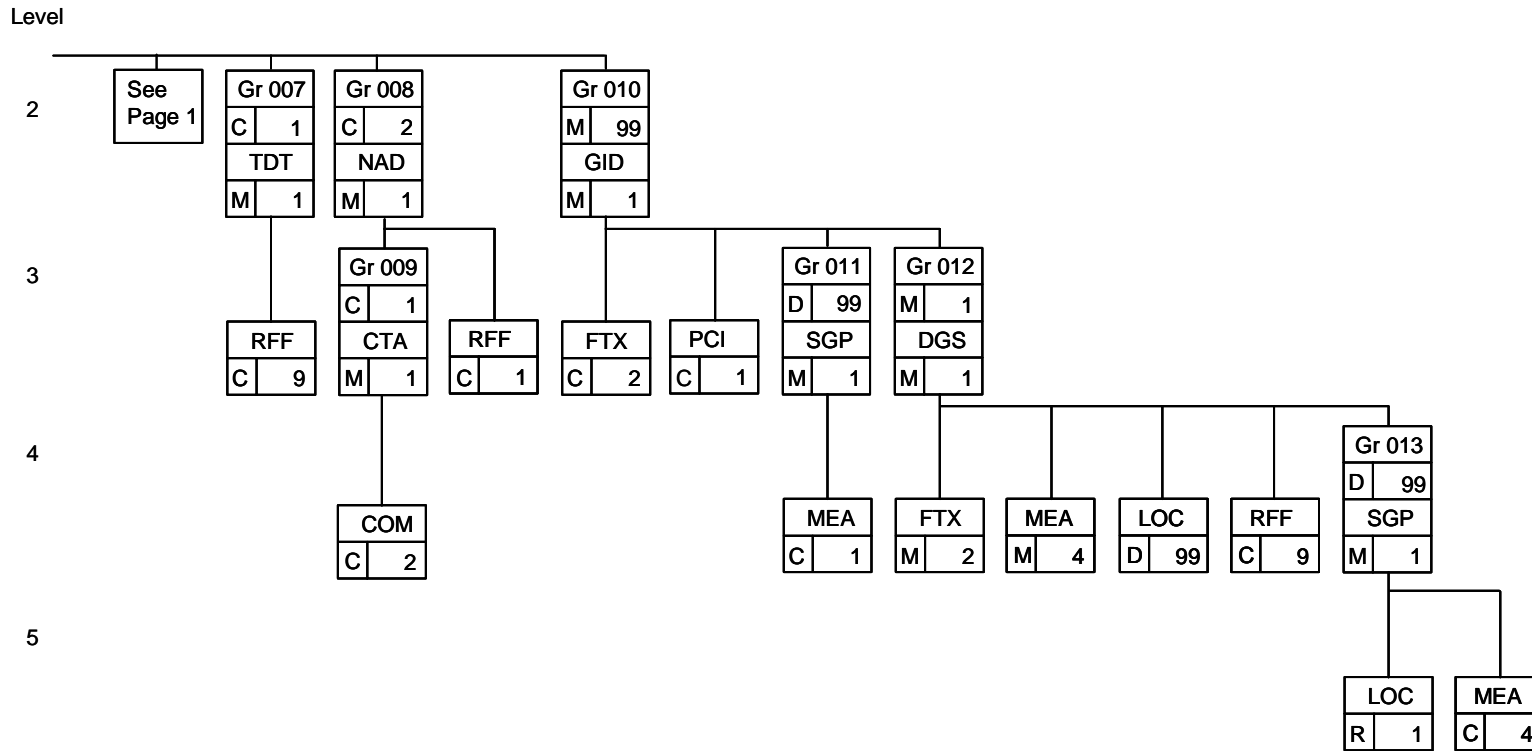

**Segment: UNH Message Header**

**Position:** 0010

**Group:**

**Level:** 0

**Usage:** Mandatory

**Max Use:** 1

**Purpose:** A service segment starting and uniquely identifying a message. The message type code for the Dangerous goods notification message is IFTDGN.

Note: Dangerous goods notification messages conforming to this document must contain the following data in segment UNH, composite S009:

Data element 0065 IFTDGN 0052 D 0054 98B 0051 UN

**Comments:**

**Notes:** *Sample segment :*  
*UNH+6700001+IFTDGN:D:98B:UN'*

**Data Element Summary**

	<u>Data Element</u>	<u>Component Element</u>	<u>Name</u>	<u>UN/EDIFACT</u>
M	0062		MESSAGE REFERENCE NUMBER <i>Sender's unique message reference</i>	M an..14
M	S009		MESSAGE IDENTIFIER	M
M		0065	Message type identifier <i>IFTDGN Dangerous goods notification message</i>	M an..6
M		0052	Message type version number <i>D Draft version/UN/EDIFACT Directory</i>	M an..3
M		0054	Message type release number <i>98B Release 1998 – B</i>	M an..3
M		0051	Controlling agency <i>UN UN/ECE/TRADE/WP.4</i>	M an..2
X		0057	Association assigned code <i>Note! Not allowed</i>	C an..6
X	0068		COMMON ACCESS REFERENCE	C an..35
X	S010		STATUS OF THE TRANSFER	C
X		0070	Sequence message transfer number	M n..2
X		0073	First/last sequence message transfer indication	C a1

**Segment:** **BGM** Beginning of Message  
**Position:** 0020  
**Group:**  
**Level:** 0  
**Usage:** Mandatory  
**Max Use:** 1  
**Purpose:** A segment to indicate the beginning of the message by identifying the message by a document/message number. It is recommended to sequentially number the messages relating to the same conveyance/voyage of the means of transport. Update (change or replace) messages can be accommodated using Message function code together with the Reference to previous message (in RFF segment) quoting the document/message number of the message being updated by this message.

**Comments:**

**Notes:** *Sample segment :*  
*BGM+89N +74952209460+9'*

**Data Element Summary**

	<u>Data Element</u>	<u>Component Element</u>	<u>Name</u>	<u>UN/EDIFACT</u>
R	C002		DOCUMENT/MESSAGE NAME	C
R		1001	Document/message name, coded	C an..3
			89N <i>Dangerous Goods Notification for all other cargo (other than bulk in tanker)</i>	
			89T <i>Dangerous Goods Notification of Bulk Cargo in Tanker vessel</i>	
			89A <i>Dangerous Goods Request (preceeding dangerous goods notification, valid with certain substances)</i>	
X		1131	Code list qualifier	C an..3
X		3055	Code list responsible agency, coded	C an..3
X		1000	Document/message name	C an..35
R	C106		DOCUMENT/MESSAGE IDENTIFICATION	C
R		1004	Document/message number	C an..35
			<i>Sender's unique reference number</i>	
X		1056	Version	C an..9
X		1060	Revision number	C an..6
R	1225		MESSAGE FUNCTION, CODED	C an..3
			9 <i>Original</i>	
			5 <i>Replace</i>	
			1 <i>Cancellation</i>	
X	4343		RESPONSE TYPE, CODED	C an..3

**Segment:** **DTM** Date/Time/Period  
**Position:** 0030  
**Group:**  
**Level:** 0  
**Usage:** Required  
**Max Use:** 9  
**Purpose:** A segment to indicate a date and time applying to the whole message, such as date and time of document/message issue.

**Comments:**

**Notes:** *Sample segment :*  
*DTM+137:200301141246:203'*

**Data Element Summary**

	<u>Data Element</u>	<u>Component Element</u>	<u>Name</u>	<u>UN/EDIFACT</u>
M	C507		DATE/TIME/PERIOD	M
M		2005	Date/time/period qualifier 137 <i>Document/message date/time</i>	M an..3
R		2380	Date/time/period <i>Date/time that the message was prepared (UTC date/time)</i>	C an..35
R		2379	Date/time/period format qualifier 203 <i>CCYYMMDDHHMM</i>	C an..3

**Segment:** **FTX** Free Text  
**Position:** 0040  
**Group:**  
**Level:** 1  
**Usage:** Conditional  
**Max Use:** 9  
**Purpose:** To provide free form or coded text information.  
**Comments:** May only be completed if Message function, coded in BGM contains a coded value other than 'original message'.  
**Notes:**

## Data Element Summary

	<u>Data</u>	<u>Component</u>		<u>UN/EDIFACT</u>
	<u>Element</u>	<u>Element</u>	<u>Name</u>	
M	4451		TEXT SUBJECT QUALIFIER <i>CHG</i> <i>Change information</i>	M an..3
X	4453		TEXT FUNCTION, CODED	C an..3
R	C107		TEXT REFERENCE	C
M		4441	Free text identification	M an..17
X		1131	Code list qualifier	C an..3
X		3055	Code list responsible agency, coded	C an..3
X	C108		TEXT LITERAL	C
X		4440	Free text	M an..70
X		4440	Free text	C an..70
X		4440	Free text	C an..70
X		4440	Free text	C an..70
X		4440	Free text	C an..70
X	3453		LANGUAGE, CODED	C an..3
X	4447		TEXT FORMATTING, CODED	C an..3

**Segment:** **FTX** Free Text  
**Position:** 0040  
**Group:**  
**Level:** 1  
**Usage:** Conditional  
**Max Use:** 9  
**Purpose:** To provide free form or coded text information.  
**Comments:**  
**Notes:**

## Data Element Summary

	<u>Data</u>	<u>Component</u>		<u>UN/EDIFACT</u>
	<u>Element</u>	<u>Element</u>	<u>Name</u>	
M	4451		TEXT SUBJECT QUALIFIER <i>ACB Additional information</i>	M an..3
X	4453		TEXT FUNCTION, CODED	C an..3
X	C107		TEXT REFERENCE	C
X		4441	Free text identification	M an..17
X		1131	Code list qualifier	C an..3
X		3055	Code list responsible agency, coded	C an..3
R	C108		TEXT LITERAL	C
M		4440	Free text	M an..70
O		4440	Free text	C an..70
O		4440	Free text	C an..70
O		4440	Free text	C an..70
O		4440	Free text	C an..70
X	3453		LANGUAGE, CODED	C an..3
X	4447		TEXT FORMATTING, CODED	C an..3

**Segment:** **FTX** Free Text  
**Position:** 0040  
**Group:**  
**Level:** 1  
**Usage:** Conditional  
**Max Use:** 9  
**Purpose:** To provide free form or coded text information.  
**Comments:**  
**Notes:**

## Data Element Summary

	<u>Data Element</u>	<u>Component Element</u>	<u>Name</u>	<u>UN/EDIFACT</u>
M	4451		TEXT SUBJECT QUALIFIER <i>COF</i> Certificate of fitness <i>COS</i> Certificate of fitness stowage	M an..3
X	4453		TEXT FUNCTION, CODED	C an..3
X	C107		TEXT REFERENCE	C
X		4441	Free text identification	M an..17
X		1131	Code list qualifier	C an..3
X		3055	Code list responsible agency, coded	C an..3
X	C108		TEXT LITERAL	C
X		4440	Free text	M an..70
X		4440	Free text	C an..70
X		4440	Free text	C an..70
X		4440	Free text	C an..70
X		4440	Free text	C an..70
X	3453		LANGUAGE, CODED	C an..3
X	4447		TEXT FORMATTING, CODED	C an..3

**Segment:** **HAN** Handling Instructions

**Position:** 0500

**Group:**

**Level:** 0

**Usage:** Conditional

**Max Use:** 1

**Purpose:** A segment to report a handling operation to be taken on the hazardous cargo of the consignment. Some ports allow to report one handling operation of hazardous cargo per consignment in the IFTDGN message.

**Comments:**

**Notes:** *Sample segment :*  
*HAN+LLO'*

Data Element Summary				
	<u>Data Element</u>	<u>Component Element</u>	<u>Name</u>	<u>UN/EDIFACT</u>
R	C524		HANDLING INSTRUCTIONS	C
R		4079	Handling instructions, coded	C an..3
			<i>LDI Discharge action</i>	
			<i>LLO Load action</i>	
			<i>T In transit</i>	
X		1131	Code list qualifier	C an..3
X		3055	Code list responsible agency, coded	C an..3
X		4078	Handling instructions	C an..70
X	C218		HAZARDOUS MATERIAL	C
X		7419	Hazardous material class code, identification	C an..4
X		1131	Code list qualifier	C an..3
X		3055	Code list responsible agency, coded	C an..3
X		7418	Hazardous material class	C an..35

**Segment:** **RFF** Reference  
**Position:** 0070 (Trigger Segment)  
**Group:** Segment Group 1 (Reference) Required Max Use = 9  
**Level:** 1  
**Usage:** Required  
**Max Use:** 1  
**Purpose:** A segment to express a reference which applies to the entire message. The reference to be qualified: - Carrier's agent reference number - Freight forwarders reference number.

**Comments:**  
**Notes:** *Sample segment :*  
**RFF+AA Y:2700303NLROT'**

*Segment must occur at least once to specify the carrier's agent reference number (C506.e1153 = 'AAY')*

## Data Element Summary

	<u>Data Element</u>	<u>Component Element</u>	<u>Name</u>	<u>UN/EDIFACT</u>
M	C506		REFERENCE <i>At least Carrier's agent reference must be specified.</i>	M
M		1153	Reference qualifier AA Y <i>Carrier's agent reference number</i>	M an..3
R		1154	Reference number <i>Reference number</i>	C an..35
X		1156	Line number	C an..6
X		4000	Reference version number	C an..35
X		1060	Revision number	C an..6

**Segment:** **RFF** Reference  
**Position:** 0070 (Trigger Segment)  
**Group:** Segment Group 1 (Reference) Required Max Use = 9  
**Level:** 1  
**Usage:** Conditional  
**Max Use:** 1  
**Purpose:** A segment to express a reference which applies to the entire message. Reference to previous message  
**Comments:**  
**Notes:** *In case of replacement message (BGM e1225 = '5'), segment must occur to specify the reference number (BGM C106.e1004) of the message being replaced.*

## Data Element Summary

	<u>Data Element</u>	<u>Component Element</u>	<u>Name</u>	<u>UN/EDIFACT</u>
M	C506		REFERENCE <i>At least Carrier's agent reference must be specified.</i>	M
M		1153	Reference qualifier ACW <i>Reference number to previous message</i> FF <i>Reference number assigned by the freight forwarder</i>	M an..3
R		1154	Reference number <i>Reference number</i>	C an..35
X		1156	Line number	C an..6
X		4000	Reference version number	C an..35
X		1060	Revision number	C an..6

**Segment:** **TDT** Details of Transport  
**Position:** 0100 (Trigger Segment)  
**Group:** Segment Group 2 (Details of Transport) Required Max Use = 1  
**Level:** 1  
**Usage:** Mandatory  
**Max Use:** 1  
**Purpose:** A segment to indicate the transport information related to the visit of a means of transport in the port. The transport details to be specified: - Main transport

**Comments:****Notes:***Sample segment :*

*TDT+20+0303+1:SEA+13+MAEU:172::MAERSK SEALAND+++9190755::LEDA  
 MAERSK:DK'*

**Data Element Summary**

	<u>Data Element</u>	<u>Component Element</u>	<u>Name</u>	<u>UN/EDIFACT</u>
M	8051		TRANSPORT STAGE QUALIFIER <i>20 Main-carriage transport</i>	M an..3
O	8028		CONVEYANCE REFERENCE NUMBER	C an..17
R	C220		MODE OF TRANSPORT	C
R		8067	Mode of transport, coded <i>1 Maritime transport</i>	C an..3
X		8066	Mode of transport	C an..17
O	C228		TRANSPORT MEANS	C
O		8179	Type of means of transport identification <i>Vessel type coded according to Lloyd's Register of Shipping's code table for vessel types. 13 Ocean vessel</i>	C an..8
O		8178	Type of means of transport	C an..17
X	C040		CARRIER	C
X		3127	Carrier identification	C an..17
X		1131	Code list qualifier	C an..3
X		3055	Code list responsible agency, coded	C an..3
X		3128	Carrier name	C an..35
X	8101		TRANSIT DIRECTION, CODED	C an..3
X	C401		EXCESS TRANSPORTATION INFORMATION	C
X		8457	Excess transportation reason, coded	M an..3
X		8459	Excess transportation responsibility, coded	M an..3
X		7130	Customer authorization number	C an..17
O	C222		TRANSPORT IDENTIFICATION	C
O		8213	Id. of means of transport identification <i>Identification of vessel in accordance with Lloyd's Register of Shipping (Lloyd's Number).</i>	C an..9
X		1131	Code list qualifier	C an..3
X		3055	Code list responsible agency, coded	C an..3
O		8212	Id. of the means of transport <i>Vessel name (free text)</i>	C an..35
O		8453	Nationality of means of transport, coded <i>Nationality of vessel coded in accordance with Lloyd's Flag table.</i>	C an..3
X	8281		TRANSPORT OWNERSHIP, CODED	C an..3

**Segment:** **RFF** Reference (TDT.RFF)  
**Position:** 0110  
**Group:** Segment Group 2 (Details of Transport)  
**Level:** 2  
**Usage:** Required  
**Max Use:** 9  
**Purpose:** A segment to indicate the reference to be qualified as allocated by an authority, Port Visit ID, at SMA.

**Comments:**

**Notes:** *Sample segment :*  
*RFF+SSX:C5205CC'*

**Data Element Summary**

	<u>Data Element</u>	<u>Component Element</u>	<u>Name</u>	<u>UN/EDIFACT</u>
M	C506		REFERENCE	M
M		1153	Reference qualifier SSX	M an..3
			<i>SHIP'S STAY REFERENCE NUMBER</i> <i>Reference number assigned by the authority in the port to a certain call of the vessel in that port.</i>	
R		1154	Reference number Port visit ID	C an..35
X		1156	Line number	C an..6
X		4000	Reference version number	C an..35
X		1060	Revision number	C an..6

**Segment:** **RFF** Reference (TDT.RFF)  
**Position:** 0110  
**Group:** Segment Group 2 (Details of Transport)  
**Level:** 2  
**Usage:** Conditional  
**Max Use:** 9  
**Purpose:** A segment to indicate the transport licence reference number(s) of the main transport.

**Comments:**

**Notes:** *Sample segment :*  
*RFF+VM:OYXZ2'*

**Data Element Summary**

	<u>Data Element</u>	<u>Component Element</u>	<u>Name</u>	<u>UN/EDIFACT</u>
M	C506		REFERENCE	M
M		1153	Reference qualifier <i>VM</i> <i>Vessel identification radio call sign</i>	M an..3
R		1154	Reference number <i>Radio Call Sign</i>	C an..35
X		1156	Line number	C an..6
X		4000	Reference version number	C an..35
X		1060	Revision number	C an..6

**Segment:** **LOC** Place/Location Identification (TDT.LOC)  
**Position:** 0120  
**Group:** Segment Group 2 (Details of Transport)  
**Level:** 2  
**Usage:** Required  
**Max Use:** 10  
**Purpose:** A segment to indicate locations related to the arrival of the means of transport.  
**Comments:**  
**Notes:** *Sample segment :*  
*LOC+153+NLRTM:139:6:ROTTERDAM'*

## Data Element Summary

	<u>Data Element</u>	<u>Component Element</u>	<u>Name</u>	<u>UN/EDIFACT</u>
M	3227		PLACE/LOCATION QUALIFIER <i>153 Port of call</i>	M an..3
R	C517		LOCATION IDENTIFICATION	C
R		3225	Place/location identification <i>UNLocode</i>	C an..25
X		1131	Code list qualifier	C an..3
X		3055	Code list responsible agency, coded	C an..3
O		3224	Place/location <i>Port name (free text)..</i>	C an..70
O	C519		RELATED LOCATION ONE IDENTIFICATION	C
R		3223	Related place/location one identification	C an..25
X		1131	Code list qualifier	C an..3
X		3055	Code list responsible agency, coded	C an..3
X		3222	Related place/location one	C an..70
O	C553		RELATED LOCATION TWO IDENTIFICATION	C
R		3233	Related place/location two identification	C an..25
X		1131	Code list qualifier	C an..3
X		3055	Code list responsible agency, coded	C an..3
X		3232	Related place/location two	C an..70
X	5479		RELATION, CODED	C an..3

**Segment:** **LOC** Place/Location Identification (TDT.LOC)  
**Position:** 0120  
**Group:** Segment Group 2 (Details of Transport)  
**Level:** 2  
**Usage:** Conditional  
**Max Use:** 10  
**Purpose:** A segment to indicate locations related to the arrival of the means of transport.  
 Next port is used as location code of contact person.  
**Comments:**  
**Notes:**

## Data Element Summary

	<u>Data Element</u>	<u>Component Element</u>	<u>Name</u>	<u>UN/EDIFACT</u>
M	3227		<b>PLACE/LOCATION QUALIFIER</b> <i>POO</i> Place of origin <i>61</i> Next port of call	M an..3
R	C517		<b>LOCATION IDENTIFICATION</b>	C
R		3225	Place/location identification <i>UNLocode</i>	C an..25
X		1131	Code list qualifier	C an..3
X		3055	Code list responsible agency, coded	C an..3
O		3224	Place/location <i>Port name (free text)..</i>	C an..70
O	C519		<b>RELATED LOCATION ONE IDENTIFICATION</b>	C
R		3223	Related place/location one identification	C an..25
X		1131	Code list qualifier	C an..3
X		3055	Code list responsible agency, coded	C an..3
X		3222	Related place/location one	C an..70
O	C553		<b>RELATED LOCATION TWO IDENTIFICATION</b>	C
R		3233	Related place/location two identification	C an..25
X		1131	Code list qualifier	C an..3
X		3055	Code list responsible agency, coded	C an..3
X		3232	Related place/location two	C an..70
X	5479		<b>RELATION, CODED</b>	C an..3

**Segment:** **DTM** Date/Time/Period (TDT.DTM)  
**Position:** 0130  
**Group:** Segment Group 2 (Details of Transport)  
**Level:** 2  
**Usage:** Required  
**Max Use:** 2  
**Purpose:** A segment to indicate expected time and date of arrival. The date/time to be qualified: -  
 Estimated date/time of departure  
**Comments:** ETD (C507.2005=133) is required  
**Notes:** *Sample segment :*  
*DTM+133:200301132300:203'*

## Data Element Summary

	<u>Data Element</u>	<u>Component Element</u>	<u>Name</u>	<u>UN/EDIFACT</u>
M	C507		DATE/TIME/PERIOD	M
M		2005	Date/time/period qualifier 133 <i>Departure date/time, estimated</i>	M an..3
R		2380	Date/time/period <i>Estimated date/time of arrival/departure (local date/time)</i>	C an..35
R		2379	Date/time/period format qualifier 203 <i>CCYYMMDDHHMM</i>	C an..3

**Segment:** **DTM** Date/Time/Period (TDT.DTM)  
**Position:** 0130  
**Group:** Segment Group 2 (Details of Transport)  
**Level:** 2  
**Usage:** Conditional  
**Max Use:** 2  
**Purpose:** A segment to indicate expected time and date of arrival. The date/time to be qualified: -  
 Estimated date/time of arrival

**Comments:**

**Notes:** *Sample segment :*  
*DTM+132:200301132300:203'*

**Data Element Summary**

	<u>Data Element</u>	<u>Component Element</u>	<u>Name</u>	<u>UN/EDIFACT</u>
M	C507		DATE/TIME/PERIOD	M
M		2005	Date/time/period qualifier 132 <i>Arrival date/time, estimated</i>	M an..3
R		2380	Date/time/period <i>Estimated date/time of arrival/departure (local date/time)</i>	C an..35
R		2379	Date/time/period format qualifier 203 <i>CCYYMMDDHHMM</i>	C an..3

**Segment:** **NAD** Name and Address  
**Position:** 0150 (Trigger Segment)  
**Group:** Segment Group 3 (Name and Address) Required Max Use = 6  
**Level:** 1  
**Usage:** Mandatory  
**Max Use:** 1  
**Purpose:** A segment to identify a party's name, address and function relevant to the entire message. The functions to be qualified: - Carrier - either Carrier's agent or Freight forwarder  
 Remark: the place of this segment group in the message is derived from the single consignment based (IFTMxx) messages (and not the IFCSUM message). e.g.: Message recipient, Message sender, Acknowledgement recipient, Notify party (in case of calamity).

**Comments:**

**Notes:** *Sample segment :*  
**NAD+MS++REDERIET A P MOELLER:MAERSK SEALAND:50**  
**ESPLANADEN:DK1098 COPENHAGEN'**  
**NAD+CG++MAERSK BENELUX B.V.'**

**Data Element Summary**

	<u>Data Element</u>	<u>Component Element</u>	<u>Name</u>	<u>UN/EDIFACT</u>
M	3035		<b>PARTY QUALIFIER</b>	M an..3
			<i>CG Carrier's agent</i>	
			<i>MS Document/message issuer/sender</i>	
O	C082		<b>PARTY IDENTIFICATION DETAILS</b>	C
M		3039	<b>Party identification</b>	M an..35
X		1131	<b>Code list qualifier</b>	C an..3
X		3055	<b>Code list responsible agency, coded</b>	C an..3
O	C058		<b>NAME AND ADDRESS</b>	C
			<i>Party name/address (unstructured).</i>	
M		3124	<b>Name and address line</b>	M an..35
O		3124	<b>Name and address line</b>	C an..35
O		3124	<b>Name and address line</b>	C an..35
O		3124	<b>Name and address line</b>	C an..35
O		3124	<b>Name and address line</b>	C an..35
O	C080		<b>PARTY NAME</b>	C
M		3036	<b>Party name</b>	M an..35
O		3036	<b>Party name</b>	C an..35
O		3036	<b>Party name</b>	C an..35
X		3036	<b>Party name</b>	C an..35
X		3036	<b>Party name</b>	C an..35
X		3045	<b>Party name format, coded</b>	C an..3
O	C059		<b>STREET</b>	C
M		3042	<b>Street and number/p.o. box</b>	M an..35
O		3042	<b>Street and number/p.o. box</b>	C an..35
O		3042	<b>Street and number/p.o. box</b>	C an..35
X		3042	<b>Street and number/p.o. box</b>	C an..35
O	3164		<b>CITY NAME</b>	C an..35
O	3229		<b>COUNTRY SUB-ENTITY IDENTIFICATION</b>	C an..9
O	3251		<b>POSTCODE IDENTIFICATION</b>	C an..9
O	3207		<b>COUNTRY, CODED</b>	C an..3

**Segment:** **CTA** Contact Information (NAD.CTA)  
**Position:** 0170 (Trigger Segment)  
**Group:** Segment Group 4 (Contact Information) Required Max Use=2  
**Level:** 2  
**Usage:** Mandatory  
**Max Use:** 1  
**Purpose:** A segment to identify a person or department within a party.  
**Comments:**  
**Notes:** *Sample segment :*  
*CTA+IC+:J.N. BRUIJNES'*

#### Data Element Summary

	<u>Data Element</u>	<u>Component Element</u>	<u>Name</u>	<u>UN/EDIFACT</u>
R	3139		CONTACT FUNCTION, CODED <i>IC Information contact</i>	C an..3
R	C056		DEPARTMENT OR EMPLOYEE DETAILS	C
X		3413	Department or employee identification	C an..17
R		3412	Department or employee <i>Contact name (free text)</i>	C an..35

**Segment:** **COM** Communication Contact (NAD.CTA.COM)  
**Position:** 0180  
**Group:** Segment Group 4 (Contact Information)  
**Level:** 3  
**Usage:** Required  
**Max Use:** 9  
**Purpose:** A segment to identify a communication number of a person or department to whom communication should be directed specifying telephone number and telefax number.

**Comments:**  
**Notes:** *Sample segment :*  
*COM+0105030771:TE'*  
*Segment is sent twice to specify both contact telephone and fax number.*

## Data Element Summary

	<u>Data Element</u>	<u>Component Element</u>	<u>Name</u>	<u>UN/EDIFACT</u>
M	C076		COMMUNICATION CONTACT	M
M		3148	Communication number <i>Contact telephone or fax number</i>	M an..512
M		3155	Communication channel qualifier <i>FX Telefax</i> <i>TE Telephone</i>	M an..3

**Segment:** **COM** Communication Contact (NAD.CTA.COM)  
**Position:** 0180  
**Group:** Segment Group 4 (Contact Information)  
**Level:** 3  
**Usage:** Dependent  
**Max Use:** 9  
**Purpose:** A segment to identify a communication number of a person or department to whom communication should be directed specifying e-mail address.

**Comments:**

**Notes:** *Sample segment :*  
*COM+abc.def@company.com:EM'*

**Data Element Summary**

	<u>Data Element</u>	<u>Component Element</u>	<u>Name</u>	<u>UN/EDIFACT</u>
M	C076		COMMUNICATION CONTACT	M
M		3148	Communication number <i>Contact telephone or fax number</i>	M an..512
M		3155	Communication channel qualifier <i>EM E-mail address</i>	M an..3

**Segment:** **EQD** Equipment Details  
**Position:** 0200 (Trigger Segment)  
**Group:** Segment Group 5 (Equipment Details)      Conditional Max Use = 999  
**Level:** 1  
**Usage:** Mandatory  
**Max Use:** 1  
**Purpose:** A segment to specify the equipment identification and the equipment size and type of the equipment used in the transport. The equipment to be qualified:    - Barge, lighter    - Container    - Trailer

**Comments:**  
**Notes:**

**Data Element Summary**

	<u>Data Element</u>	<u>Component Element</u>	<u>Name</u>	<u>UN/EDIFACT</u>
M	8053		EQUIPMENT QUALIFIER <i>CN                      Container</i>	M an..3
O	C237		EQUIPMENT IDENTIFICATION	C
R		8260	Equipment identification number <i>Container number</i>	C an..17
X		1131	Code list qualifier	C an..3
X		3055	Code list responsible agency, coded	C an..3
X		3207	Country, coded	C an..3
O	C224		EQUIPMENT SIZE AND TYPE	C
O		8155	Equipment size and type identification <i>Equipment size/type coded in accordance with ISO 6346 (.1 or .2).</i>	C an..10
X		1131	Code list qualifier	C an..3
X		3055	Code list responsible agency, coded	C an..3
O		8154	Equipment size and type	C an..35
X	8077		EQUIPMENT SUPPLIER, CODED	C an..3
X	8249		EQUIPMENT STATUS, CODED	C an..3
O	8169		FULL/EMPTY INDICATOR, CODED 4 <i>Empty</i> <i>Used when the container is contaminated or carrying cargo residue.</i> 5 <i>Full</i>	C an..3

**Segment:** **MEA** Measurements (EQD.MEA)  
**Position:** 0210  
**Group:** Segment Group 5 (Equipment Details)  
**Level:** 2  
**Usage:** Conditional  
**Max Use:** 1  
**Purpose:** To specify physical measurements, including dimension tolerances, weights and counts.  
 The measurement to be qualified: - Net weight - Gross weight

**Comments:**  
**Notes:**

#### Data Element Summary

	<u>Data Element</u>	<u>Component Element</u>	<u>Name</u>	<u>UN/EDIFACT</u>
M	6311		MEASUREMENT PURPOSE QUALIFIER <i>AAE Measurement</i>	M an..3
R	C502		MEASUREMENT DETAILS	C
R		6313	Property measured, coded <i>AAL Net weight</i> <i>G Gross weight</i> <i>T19 Net Explosive Content (powder weight)</i>	C an..3
X		6321	Measurement significance, coded	C an..3
X		6155	Measurement attribute identification	C an..17
X		6154	Measurement attribute	C an..70
R	C174		VALUE/RANGE	C
M		6411	Measure unit qualifier <i>KGM Kilogram</i>	M an..3
R		6314	Measurement value <i>Net/gross/net explosive weight</i>	C an..18
X		6162	Range minimum	C n..18
X		6152	Range maximum	C n..18
X		6432	Significant digits	C n..2
X	7383		SURFACE/LAYER INDICATOR, CODED	C an..3

**Segment:** **CNI** Consignment Information  
**Position:** 0230 (Trigger Segment)  
**Group:** Segment Group 6 (Consignment Information) Mandatory Max Use = 999  
**Level:** 1  
**Usage:** Mandatory  
**Max Use:** 1  
**Purpose:** A segment to identify the consignment and to indicate whether the consignment is to be loaded, discharged or in transit.  
**Comments:**  
**Notes:** *Sample segment :*  
*CNI+1+FRMC07450'*

## Data Element Summary

	<u>Data Element</u>	<u>Component Element</u>	<u>Name</u>	<u>UN/EDIFACT</u>
R	1490		CONSOLIDATION ITEM NUMBER <i>Sequential number of the consignment within the message</i>	C n..4
D	C503		DOCUMENT/MESSAGE DETAILS	C
R		1004	Document/message number <i>Identification number of the consignment - Bill of Lading number if the handling action is Discharge or Transit, booking number if the handling action is Load.</i>	C an..35
X		1373	Document/message status, coded	C an..3
X		1366	Document/message source	C an..70
X		3453	Language, coded	C an..3
X		1056	Version	C an..9
X		1060	Revision number	C an..6
X	1312		CONSIGNMENT LOAD SEQUENCE NUMBER	C n..4

**Segment:** **HAN** Handling Instructions (CNL.HAN)  
**Position:** 0240  
**Group:** Segment Group 6 (Consignment Information)  
**Level:** 2  
**Usage:** Conditional  
**Max Use:** 1  
**Purpose:** A segment to report a handling operation to be taken on the hazardous cargo of the consignment. Some ports allow to report one handling operation of hazardous cargo per consignment in the IFTDGN message.

**Comments:**  
**Notes:** *Sample segment :*  
*HAN+LLO'*

## Data Element Summary

	<u>Data Element</u>	<u>Component Element</u>	<u>Name</u>	<u>UN/EDIFACT</u>
R	C524		<b>HANDLING INSTRUCTIONS</b>	C
R		4079	<b>Handling instructions, coded</b> <i>LDI Discharge action</i> <i>LLO Load action</i> <i>T In transit</i>	C an..3
X		1131	<b>Code list qualifier</b>	C an..3
X		3055	<b>Code list responsible agency, coded</b>	C an..3
X		4078	<b>Handling instructions</b>	C an..70
X	C218		<b>HAZARDOUS MATERIAL</b>	C
X		7419	<b>Hazardous material class code, identification</b>	C an..4
X		1131	<b>Code list qualifier</b>	C an..3
X		3055	<b>Code list responsible agency, coded</b>	C an..3
X		7418	<b>Hazardous material class</b>	C an..35

**Segment:** **DTM** Date/Time/Period (CNI.DTM)  
**Position:** 0250  
**Group:** Segment Group 6 (Consignment Information)  
**Level:** 2  
**Usage:** Conditional  
**Max Use:** 4  
**Purpose:** A segment to indicate expected time and date of handling, arrival and departure. The date/time to be qualified: - Estimated date/time of arrival - Estimated date/time of departure

**Comments:**

**Notes:** *Sample segment :*  
*DTM+132:200301132300:203'*

**Data Element Summary**

	<u>Data Element</u>	<u>Component Element</u>	<u>Name</u>	<u>UN/EDIFACT</u>
M	C507		DATE/TIME/PERIOD	M
M		2005	Date/time/period qualifier	M an..3
			132 Arrival date/time, estimated	
			133 Departure date/time, estimated	
R		2380	Date/time/period	C an..35
			Estimated date/time of arrival/departure (local date/time)	
R		2379	Date/time/period format qualifier	C an..3
			203 CCYYMMDDHHMM	

**Segment:** **LOC** Place/Location Identification (CNLLOC)  
**Position:** 0260  
**Group:** Segment Group 6 (Consignment Information)  
**Level:** 2  
**Usage:** Required  
**Max Use:** 4  
**Purpose:** A segment to indicate locations related to the arrival of a consignment. The location to be qualified: - place/port of loading - place/port of discharge - berth (as the place where the discharge/load/in transit action is to take place) - warehouse (as the place where the consignment will be stored)

**Comments:**

**Notes:** *Sample segment :*  
*LOC+11+ARBUE:139:6:BUENOS AIRES'*

**Data Element Summary**

	<u>Data Element</u>	<u>Component Element</u>	<u>Name</u>	<u>UN/EDIFACT</u>
M	3227		<b>PLACE/LOCATION QUALIFIER</b>	<b>M an..3</b>
		9	<i>Place/port of loading</i>	
		11	<i>Place/port of discharge</i>	
R	C517		<b>LOCATION IDENTIFICATION</b>	<b>C</b>
D		3225	<b>Place/location identification</b>	<b>C an..25</b>
			<i>UNLocode</i>	
X		1131	<b>Code list qualifier</b>	<b>C an..3</b>
		139	<i>Port</i>	
X		3055	<b>Code list responsible agency, coded</b>	<b>C an..3</b>
		6	<i>UN/ECE (United Nations - Economic Commission for Europe)</i>	
O		3224	<b>Place/location</b>	<b>C an..70</b>
			<i>Port name (free text)</i>	
O	C519		<b>RELATED LOCATION ONE IDENTIFICATION</b>	<b>C</b>
R		3223	<b>Related place/location one identification</b>	<b>C an..25</b>
R		1131	<b>Code list qualifier</b>	<b>C an..3</b>
R		3055	<b>Code list responsible agency, coded</b>	<b>C an..3</b>
X		3222	<b>Related place/location one</b>	<b>C an..70</b>
O	C553		<b>RELATED LOCATION TWO IDENTIFICATION</b>	<b>C</b>
R		3233	<b>Related place/location two identification</b>	<b>C an..25</b>
X		1131	<b>Code list qualifier</b>	<b>C an..3</b>
X		3055	<b>Code list responsible agency, coded</b>	<b>C an..3</b>
X		3232	<b>Related place/location two</b>	<b>C an..70</b>
X	5479		<b>RELATION, CODED</b>	<b>C an..3</b>

**Segment:** **TDT** Details of Transport (CNI.TDT)  
**Position:** 0280 (Trigger Segment)  
**Group:** Segment Group 7 (Details of Transport) Conditional Max Use = 1  
**Level:** 2  
**Usage:** Mandatory  
**Max Use:** 1  
**Purpose:** A segment to indicate the transport information related to the visit of a means of transport in the port. The transport details to be specified: - Main transport

**Comments:**

**Notes:** *Sample segment :*  
**TDT+20+0303+1:SEA+13+MAEU:172::MAERSK SEALAND+++9190755::LEDA**  
**MAERSK:DK'**

**Data Element Summary**

	<u>Data Element</u>	<u>Component Element</u>	<u>Name</u>	<u>UN/EDIFACT</u>
M	8051		TRANSPORT STAGE QUALIFIER	M an..3
			30 On-carriage transport	
			10 Pre-carriage transport	
O	8028		CONVEYANCE REFERENCE NUMBER	C an..17
R	C220		MODE OF TRANSPORT	C
R		8067	Mode of transport, coded	C an..3
			1 Maritime transport	
X		8066	Mode of transport	C an..17
X	C228		TRANSPORT MEANS	C
X		8179	Type of means of transport identification	C an..8
X		8178	Type of means of transport	C an..17
X	C040		CARRIER	C
X		3127	Carrier identification	C an..17
X		1131	Code list qualifier	C an..3
X		3055	Code list responsible agency, coded	C an..3
X		3128	Carrier name	C an..35
X	8101		TRANSIT DIRECTION, CODED	C an..3
X	C401		EXCESS TRANSPORTATION INFORMATION	C
X		8457	Excess transportation reason, coded	M an..3
X		8459	Excess transportation responsibility, coded	M an..3
X		7130	Customer authorization number	C an..17
O	C222		TRANSPORT IDENTIFICATION	C
O		8213	Id. of means of transport identification	C an..9
			<i>Identification of vessel in accordance with Lloyd's Register of Shipping (Lloyd's Number).</i>	
X		1131	Code list qualifier	C an..3
X		3055	Code list responsible agency, coded	C an..3
O		8212	Id. of the means of transport	C an..35
			<i>Vessel name (free text)</i>	
O		8453	Nationality of means of transport, coded	C an..3
			<i>Nationality of vessel coded in accordance with Lloyd's Flag table.</i>	
X	8281		TRANSPORT OWNERSHIP, CODED	C an..3

**Segment:** **RFF** Reference (CNI.TDT.RFF)  
**Position:** 0290  
**Group:** Segment Group 7 (Details of Transport)  
**Level:** 3  
**Usage:** Conditional  
**Max Use:** 9  
**Purpose:** A segment to indicate the transport licence reference number(s) of the main transport.  
**Comments:**  
**Notes:** *Sample segment :*  
*RFF+VM:OYXZ2'*

## Data Element Summary

	<u>Data Element</u>	<u>Component Element</u>	<u>Name</u>	<u>UN/EDIFACT</u>
M	C506		REFERENCE	M
M		1153	Reference qualifier <i>VM Vessel identification radio call sign</i>	M an..3
R		1154	Reference number <i>Radio Call Sign</i>	C an..35
X		1156	Line number	C an..6
X		4000	Reference version number	C an..35
X		1060	Revision number	C an..6

**Segment:** **NAD** Name and Address (CNI.NAD)  
**Position:** 0310 (Trigger Segment)  
**Group:** Segment Group 8 (Name and Address) Conditional Max Use = 2  
**Level:** 2  
**Usage:** Mandatory  
**Max Use:** 1  
**Purpose:** To specify the name/address and their related function, either by C082 only and/or unstructured by C058 or structured by C080 thru 3207.

**Comments:**  
**Notes:**

#### Data Element Summary

	<u>Data Element</u>	<u>Component Element</u>	<u>Name</u>	<u>UN/EDIFACT</u>
M	3035		<b>PARTY QUALIFIER</b>	M an..3
			<i>FW Freight forwarder</i>	
			<i>MS Document/message issuer/sender</i>	
O	C082		<b>PARTY IDENTIFICATION DETAILS</b>	C
M		3039	<b>Party identification</b>	M an..35
X		1131	<b>Code list qualifier</b>	C an..3
X		3055	<b>Code list responsible agency, coded</b>	C an..3
O	C058		<b>NAME AND ADDRESS</b>	C
			<i>Party name/address (unstructured).</i>	
M		3124	<b>Name and address line</b>	M an..35
O		3124	<b>Name and address line</b>	C an..35
O		3124	<b>Name and address line</b>	C an..35
O		3124	<b>Name and address line</b>	C an..35
O		3124	<b>Name and address line</b>	C an..35
X	C080		<b>PARTY NAME</b>	C
X		3036	<b>Party name</b>	M an..35
X		3036	<b>Party name</b>	C an..35
X		3036	<b>Party name</b>	C an..35
X		3036	<b>Party name</b>	C an..35
X		3036	<b>Party name</b>	C an..35
X		3045	<b>Party name format, coded</b>	C an..3
X	C059		<b>STREET</b>	C
X		3042	<b>Street and number/p.o. box</b>	M an..35
X		3042	<b>Street and number/p.o. box</b>	C an..35
X		3042	<b>Street and number/p.o. box</b>	C an..35
X		3042	<b>Street and number/p.o. box</b>	C an..35
X	3164		<b>CITY NAME</b>	C an..35
X	3229		<b>COUNTRY SUB-ENTITY IDENTIFICATION</b>	C an..9
X	3251		<b>POSTCODE IDENTIFICATION</b>	C an..9
X	3207		<b>COUNTRY, CODED</b>	C an..3

**Segment:** **CTA** **Contact Information (CNLNAD.CTA)**  
**Position:** 0330 (Trigger Segment)  
**Group:** Segment Group 9 (Contact Information) Conditional Max Use=1  
**Level:** 3  
**Usage:** Mandatory  
**Max Use:** 1  
**Purpose:** A segment to identify a person or department within a party.  
**Comments:**  
**Notes:** *Sample segment :*  
*CTA+IC+:J.N. BRUIJNES'*

#### Data Element Summary

	<u>Data Element</u>	<u>Component Element</u>	<u>Name</u>	<u>UN/EDIFACT</u>
R	3139		CONTACT FUNCTION, CODED <i>IC Information contact</i>	C an..3
R	C056		DEPARTMENT OR EMPLOYEE DETAILS	C
X		3413	Department or employee identification	C an..17
R		3412	Department or employee <i>Contact name (free text)</i>	C an..35

**Segment:** **COM** Communication Contact (CNI.NAD.CTA.COM)  
**Position:** 0340  
**Group:** Segment Group 9 (Contact Information)  
**Level:** 4  
**Usage:** Conditional  
**Max Use:** 2  
**Purpose:** A segment to identify a communication number of a person or department to whom communication should be directed, e.g. e-mail number, telefax number, telephone number.

**Comments:**

**Notes:** *Sample segment :*  
*COM+0105030771:TE'*

**Data Element Summary**

	<u>Data Element</u>	<u>Component Element</u>	<u>Name</u>	<u>UN/EDIFACT</u>
M	C076		COMMUNICATION CONTACT	M
M		3148	Communication number <i>Contact telephone or fax number</i>	M an..512
M		3155	Communication channel qualifier <i>FX Telefax</i> <i>TE Telephone</i> <i>EM E-mail address</i>	M an..3

**Segment:** **RFF** Reference (CNI.NAD.RFF)  
**Position:** 0350  
**Group:** Segment Group 8 (Name and Address)  
**Level:** 3  
**Usage:** Conditional  
**Max Use:** 1  
**Purpose:** A segment to indicate the transport licence reference number(s) of the main transport.  
**Comments:**  
**Notes:** *Sample segment :*  
*RFF+VM:OYXZ2'*

## Data Element Summary

	<u>Data Element</u>	<u>Component Element</u>	<u>Name</u>	<u>UN/EDIFACT</u>
M	C506		REFERENCE	M
M		1153	Reference qualifier	M an..3
			<i>FF</i>	<i>Reference number assigned to the consignment by the freight forwarder</i>
			<i>AAY</i>	<i>Reference number assigned by a carriers agent to a transaction</i>
R		1154	Reference number	C an..35
			<i>Radio Call Sign</i>	
X		1156	Line number	C an..6
X		4000	Reference version number	C an..35
X		1060	Revision number	C an..6

**Segment:** **GID** Goods Item Details (CNI.GID)  
**Position:** 0370 (Trigger Segment)  
**Group:** Segment Group 10 (Goods Item Details) Mandatory Max Use = 99  
**Level:** 2  
**Usage:** Mandatory  
**Max Use:** 1  
**Purpose:** A segment to identify a goods item within the consignment and to indicate the heading of a goods item with the number of packages.  
**Comments:**  
**Notes:** *GID+1+40:4G::FIBREBOARD BOX++320:XJ::PAPER BAG'*

## Data Element Summary

	Data Element	Component Element	Name	UN/EDIFACT
R	1496		GOODS ITEM NUMBER <i>Sequential number of the goods item within the consignment</i>	C n..5
O	C213		NUMBER AND TYPE OF PACKAGES <i>The first composite C213 is used to give details of the selfcontained units in which the goods item is presented (the outer packaging).</i>	C
R		7224	Number of packages	C n..8
O		7065	Type of packages identification <i>Type of packages coded in accordance with UN/ECE Recommendation No. 21</i>	C an..17
X		1131	Code list qualifier	C an..3
X		3055	Code list responsible agency, coded	C an..3
O		7064	Type of packages <i>Type of packages (free text)</i>	C an..35
X		7233	Packaging related information, coded	C an..3
X	C213		NUMBER AND TYPE OF PACKAGES	C
X		7224	Number of packages	C n..8
X		7065	Type of packages identification	C an..17
X		1131	Code list qualifier	C an..3
X		3055	Code list responsible agency, coded	C an..3
X		7064	Type of packages	C an..35
X		7233	Packaging related information, coded	C an..3
O	C213		NUMBER AND TYPE OF PACKAGES <i>The third composite C213 is to be used to give details of the non-selfcontained units within the self-contained units (the most inner packaging within outer or within any intermediate packaging).</i>	C
R		7224	Number of packages	C n..8
O		7065	Type of packages identification <i>Type of packages coded in accordance with UN/ECE Recommendation No. 21</i>	C an..17
X		1131	Code list qualifier	C an..3
X		3055	Code list responsible agency, coded	C an..3
O		7064	Type of packages <i>Type of packages (free text).</i>	C an..35
X		7233	Packaging related information, coded	C an..3

**Segment:** **FTX** Free Text (CNI.GID.FTX)  
**Position:** 0380  
**Group:** Segment Group 10 (Goods Item Details)  
**Level:** 3  
**Usage:** Conditional  
**Max Use:** 2  
**Purpose:** To provide free form or coded text information.  
**Comments:**  
**Notes:**

## Data Element Summary

	Data Element	Component Element	Name	UN/EDIFACT
M	4451		TEXT SUBJECT QUALIFIER AAA <i>Plain description avoiding unnecessary detail</i>	M an..3
X	4453		TEXT FUNCTION, CODED	C an..3
O	C107		TEXT REFERENCE	C
M		4441	Free text identification	M an..17
X		1131	Code list qualifier	C an..3
X		3055	Code list responsible agency, coded	C an..3
O	C108		TEXT LITERAL	C
M		4440	Free text	M an..70
O		4440	Free text	C an..70
O		4440	Free text	C an..70
O		4440	Free text	C an..70
O		4440	Free text	C an..70
X	3453		LANGUAGE, CODED	C an..3
X	4447		TEXT FORMATTING, CODED	C an..3

**Segment:** **FTX** Free Text (CNI.GID.FTX)  
**Position:** 0380  
**Group:** Segment Group 10 (Goods Item Details)  
**Level:** 3  
**Usage:** Conditional  
**Max Use:** 2  
**Purpose:** To provide free form or coded text information.  
**Comments:**  
**Notes:**

## Data Element Summary

	Data Element	Component Element	Name	UN/EDIFACT
M	4451		TEXT SUBJECT QUALIFIER <i>ACB Additional information. Self explanatory.</i>	M an..3
X	4453		TEXT FUNCTION, CODED	C an..3
X	C107		TEXT REFERENCE	C
X		4441	Free text identification	M an..17
X		1131	Code list qualifier	C an..3
X		3055	Code list responsible agency, coded	C an..3
R	C108		TEXT LITERAL	C
M		4440	Free text	M an..70
O		4440	Free text	C an..70
O		4440	Free text	C an..70
O		4440	Free text	C an..70
O		4440	Free text	C an..70
X	3453		LANGUAGE, CODED	C an..3
X	4447		TEXT FORMATTING, CODED	C an..3

**Segment:** **PCI** Package Identification (CNI.GID.PCI)  
**Position:** 0390  
**Group:** Segment Group 10 (Goods Item Details)  
**Level:** 3  
**Usage:** Conditional  
**Max Use:** 1  
**Purpose:** To specify markings and labels on individual packages or physical units.  
**Comments:**  
**Notes:**

## Data Element Summary

	<u>Data Element</u>	<u>Component Element</u>	<u>Name</u>	<u>UN/EDIFACT</u>
X	4233		MARKING INSTRUCTIONS, CODED	C an..3
R	C210		MARKS & LABELS	C
M		7102	Shipping marks	M an..35
O		7102	Shipping marks	C an..35
O		7102	Shipping marks	C an..35
O		7102	Shipping marks	C an..35
O		7102	Shipping marks	C an..35
O		7102	Shipping marks	C an..35
O		7102	Shipping marks	C an..35
O		7102	Shipping marks	C an..35
O		7102	Shipping marks	C an..35
X	8275		CONTAINER/PACKAGE STATUS, CODED	C an..3
X	C827		TYPE OF MARKING	C
X		7511	Type of marking, coded	M an..3
X		1131	Code list qualifier	C an..3
X		3055	Code list responsible agency, coded	C an..3

**Segment:** **SGP** Split Goods Placement (CNI.GID. SGP)  
**Position:** 0410 (Trigger Segment)  
**Group:** Segment Group 11 (Split Goods Placement)      Dependent Max Use = 99  
**Level:** 3  
**Usage:** Mandatory  
**Max Use:** 1  
**Purpose:** A segment to identify the equipment (such as container number, barge identification, trailer identification) in which the dangerous goods is placed and the number of packages in that equipment.

**Comments:**  
**Notes:**

#### Data Element Summary

	<u>Data Element</u>	<u>Component Element</u>	<u>Name</u>	<u>UN/EDIFACT</u>
M	C237		EQUIPMENT IDENTIFICATION	M
R		8260	Equipment identification number <i>Containernumber</i>	C an..17
X		1131	Code list qualifier	C an..3
X		3055	Code list responsible agency, coded	C an..3
X		3207	Country, coded	C an..3
X	7224		NUMBER OF PACKAGES	C n..8

**Segment:** **MEA** Measurements (CNI.GID.SGP.MEA)  
**Position:** 0420  
**Group:** Segment Group 11 (Split Goods Placement)  
**Level:** 4  
**Usage:** Conditional  
**Max Use:** 1  
**Purpose:** To specify physical measurements, including dimension tolerances, weights and counts.  
 The measurement to be qualified: - Net weight - Gross weight

**Comments:**  
**Notes:**

#### Data Element Summary

	<u>Data Element</u>	<u>Component Element</u>	<u>Name</u>	<u>UN/EDIFACT</u>
M	6311		MEASUREMENT PURPOSE QUALIFIER <i>AAE Measurement</i>	M an..3
R	C502		MEASUREMENT DETAILS	C
R		6313	Property measured, coded <i>AAL Net weight</i> <i>G Gross weight</i> <i>T19 Net Explosive Content (powder weight)</i>	C an..3
X		6321	Measurement significance, coded	C an..3
X		6155	Measurement attribute identification	C an..17
X		6154	Measurement attribute	C an..70
R	C174		VALUE/RANGE	C
M		6411	Measure unit qualifier <i>KGM Kilogram</i>	M an..3
R		6314	Measurement value <i>Net/gross/net explosive weight</i>	C an..18
X		6162	Range minimum	C n..18
X		6152	Range maximum	C n..18
X		6432	Significant digits	C n..2
X	7383		SURFACE/LAYER INDICATOR, CODED	C an..3

**Segment:** **DGS** Dangerous Goods (CNI.GID.DGS)  
**Position:** 0440 (Trigger Segment)  
**Group:** Segment Group 12 (Dangerous Goods) Mandatory Max Use = 1  
**Level:** 3  
**Usage:** Mandatory  
**Max Use:** 1  
**Purpose:** A segment to indicate the dangerous goods regulation information, e.g. IMO code, UNDG number, dangerous goods class, packing group.

**Comments:**

**Notes:** *Sample segment :*  
*DGS+IMD+6.1+2876++3+6.104'*

**Data Element Summary**

	<u>Data Element</u>	<u>Component Element</u>	<u>Name</u>	<u>UN/EDIFACT</u>
R	8273		<b>DANGEROUS GOODS REGULATIONS, CODED</b> <i>IMD</i> <i>IMO IMDG code</i>	C an..3
R	C205		<b>HAZARD CODE</b>	C
M		8351	<b>Hazard code identification</b> <i>IMO class</i>	M an..7
O		8078	<b>Hazard substance/item/page number</b>	C an..7
O		8092	<b>Hazard code version number</b>	C an..10
R	C234		<b>UNDG INFORMATION</b>	C
R		7124	<b>UNDG number</b> <i>UN number.</i>	C n4
X		7088	<b>Dangerous goods flashpoint</b>	C an..8
O	C223		<b>DANGEROUS GOODS SHIPMENT FLASHPOINT</b>	C
R		7106	<b>Shipment flashpoint</b>	C n3
R		6411	<b>Measure unit qualifier</b> <i>CEL</i> <i>Celsius</i> <i>FAH</i> <i>Fahrenheit</i>	C an..3
D	8339		<b>PACKING GROUP, CODED</b> <i>1</i> <i>Great danger</i> <i>2</i> <i>Medium danger</i> <i>3</i> <i>Minor danger</i>	C an..3
O	8364		<b>EMS NUMBER</b>	C an..6
O	8410		<b>MFAG</b>	C an..4
X	8126		<b>TREM CARD NUMBER</b>	C an..10
X	C235		<b>HAZARD IDENTIFICATION PLACARD DETAILS</b>	C
X		8158	<b>Hazard identification number, upper part</b>	C an..4
X		8186	<b>Substance identification number, lower part</b>	C an4
O	C236		<b>DANGEROUS GOODS LABEL</b>	C
O		8246	<b>Dangerous goods label marking</b>	C an..4
O		8246	<b>Dangerous goods label marking</b>	C an..4
O		8246	<b>Dangerous goods label marking</b>	C an..4
X	8255		<b>PACKING INSTRUCTION, CODED</b>	C an..3
X	8325		<b>CATEGORY OF MEANS OF TRANSPORT, CODED</b>	C an..3
X	8211		<b>PERMISSION FOR TRANSPORT, CODED</b>	C an..3

**Segment:** **FTX** Free Text (CNI.GID.DGS.FTX)  
**Position:** 0450  
**Group:** Segment Group 12 (Dangerous Goods)  
**Level:** 4  
**Usage:** Mandatory  
**Max Use:** 9  
**Purpose:** A segment to specify processable supplementary information relating to the dangerous goods. The text subject to be qualified (each qualifier may occur only once): - Dangerous goods technical name - Dangerous goods additional information

**Comments:**

**Notes:** *Sample segment :*  
**FTX+AAD+++RESORCINOL'**

*Segment is used at least once to specify the dangerous goods technical name (e4451 = 'AAD')*

**Data Element Summary**

	<u>Data Element</u>	<u>Component Element</u>	<u>Name</u>	<u>UN/EDIFACT</u>
M	4451		TEXT SUBJECT QUALIFIER <i>AAD Dangerous goods, technical name</i>	M an..3
X	4453		TEXT FUNCTION, CODED	C an..3
O	C107		TEXT REFERENCE <i>If e4451 = 'AAD'</i> <i>Indication that the transport of the dangerous goods in limited quantities takes place under the provisions allowed for under chapter 18 of the IMO IMDG code.</i>	C
M		4441	Free text identification <i>TLQ Transport of dangerous goods in limited quantities</i>	M an..17
X		1131	Code list qualifier	C an..3
X		3055	Code list responsible agency, coded	C an..3
R	C108		TEXT LITERAL	C
M		4440	Free text <i>Dangerous goods technical name</i>	M an..70
O		4440	Free text <i>Dangerous goods technical name</i>	C an..70
O		4440	Free text <i>Dangerous goods technical name</i>	C an..70
O		4440	Free text <i>Dangerous goods technical name</i>	C an..70
O		4440	Free text <i>Dangerous goods technical name</i>	C an..70
X	3453		LANGUAGE, CODED	C an..3
X	4447		TEXT FORMATTING, CODED	C an..3

**Segment:** **FTX** Free Text (CNI.GID.DGS.FTX)  
**Position:** 0450  
**Group:** Segment Group 12 (Dangerous Goods)  
**Level:** 4  
**Usage:** Mandatory  
**Max Use:** 9  
**Purpose:** A segment to specify processable supplementary information relating to the dangerous goods. The text subject to be qualified (each qualifier may occur only once): - Dangerous goods technical name - Dangerous goods additional information

**Comments:**  
**Notes:**

## Data Element Summary

	<u>Data Element</u>	<u>Component Element</u>	<u>Name</u>	<u>UN/EDIFACT</u>
M	4451		TEXT SUBJECT QUALIFIER AAC Dangerous goods additional information	M an..3
X	4453		TEXT FUNCTION, CODED	C an..3
O	C107		TEXT REFERENCE If e4451 = 'AAC' Indication of the degree that the dangerous goods are marine pollutant.	C
M		4441	Free text identification P Marine pollutant PP Severe marine pollutant TLQ Transport of dangerous goods in limited quantities	M an..17
X		1131	Code list qualifier	C an..3
X		3055	Code list responsible agency, coded	C an..3
O	C108		TEXT LITERAL	C
M		4440	Free text	M an..70
O		4440	Free text	C an..70
O		4440	Free text	C an..70
O		4440	Free text	C an..70
O		4440	Free text	C an..70
X	3453		LANGUAGE, CODED	C an..3
X	4447		TEXT FORMATTING, CODED	C an..3

**Segment:** **MEA** Measurements (CNI.GID.DGS.MEA)  
**Position:** 0460  
**Group:** Segment Group 12 (Dangerous Goods)  
**Level:** 4  
**Usage:** Mandatory  
**Max Use:** 9  
**Purpose:** A segment to specify a measurement of the dangerous part of the goods item. The measurement to be qualified: - Net weight - Gross weight  
**Comments:** At least one of Net weight and Gross weight must be specified.  
**Notes:** *Sample segment :*  
**MEA+AAE+G+KGM:8302'**

## Data Element Summary

	Data Element	Component Element	Name	UN/EDIFACT
M	6311		MEASUREMENT PURPOSE QUALIFIER <i>AAE Measurement</i>	M an..3
R	C502		MEASUREMENT DETAILS	C
R		6313	Property measured, coded <i>AAL Net weight</i> <i>G Gross weight</i>	C an..3
X		6321	Measurement significance, coded	C an..3
X		6155	Measurement attribute identification	C an..17
X		6154	Measurement attribute	C an..70
R	C174		VALUE/RANGE	C
M		6411	Measure unit qualifier <i>KGM Kilogram</i>	M an..3
R		6314	Measurement value <i>Net/gross/net explosive weight</i>	C an..18
X		6162	Range minimum	C n..18
X		6152	Range maximum	C n..18
X		6432	Significant digits	C n..2
X	7383		SURFACE/LAYER INDICATOR, CODED	C an..3

**Segment:** **MEA** Measurements (CNI.GID.DGS.MEA)  
**Position:** 0460  
**Group:** Segment Group 12 (Dangerous Goods)  
**Level:** 4  
**Usage:** Mandatory  
**Max Use:** 9  
**Purpose:** A segment to specify a measurement of the dangerous part of the goods item. The measurement to be qualified: INF Class.

**Comments:**

**Notes:** *Sample segment :*  
**MEA+AAE+AEN+NMB:INF2'**

**Data Element Summary**

	<u>Data Element</u>	<u>Component</u>		<u>UN/EDIFACT</u>
		<u>Element</u>	<u>Name</u>	
M	6311		MEASUREMENT PURPOSE QUALIFIER <i>AAE Measurement</i>	M an..3
R	C502		MEASUREMENT DETAILS	C
R		6313	Property measured, coded <i>AEN Radioactive index of transport. SMA uses this for defining the INF Class.</i>	C an..3
X		6321	Measurement significance, coded	C an..3
X		6155	Measurement attribute identification	C an..17
X		6154	Measurement attribute	C an..70
R	C174		VALUE/RANGE	C
M		6411	Measure unit qualifier <i>NMB INF Class</i>	M an..3
R		6314	Measurement value <i>INF1, INF2 or INF3</i>	C an..18
X		6162	Range minimum	C n..18
X		6152	Range maximum	C n..18
X		6432	Significant digits	C n..2
X	7383		SURFACE/LAYER INDICATOR, CODED	C an..3

**Segment:** **LOC** Place/Location Identification (CNI.GID.DGS.LOC)  
**Position:** 0470  
**Group:** Segment Group 12 (Dangerous Goods)  
**Level:** 4  
**Usage:** Dependent  
**Max Use:** 99  
**Purpose:** To identify a country/place/location/related location in case the goods are not contained in container/equipment.  
**Comments:**  
**Notes:**

**Data Element Summary**

	<u>Data Element</u>	<u>Component Element</u>	<u>Name</u>	<u>UN/EDIFACT</u>
M	3227		PLACE/LOCATION QUALIFIER <i>147 Stowage cell</i>	M an..3
R	C517		LOCATION IDENTIFICATION	C
R		3225	Place/location identification <i>Stow position on board the vessel in ISO format : BBBRRTT</i>	C an..25
X		1131	Code list qualifier	C an..3
X		3055	Code list responsible agency, coded	C an..3
X		3224	Place/location	C an..70
O	C519		RELATED LOCATION ONE IDENTIFICATION	C
O		3223	Related place/location one identification	C an..25
X		1131	Code list qualifier	C an..3
X		3055	Code list responsible agency, coded	C an..3
O		3222	Related place/location one	C an..70
X	C553		RELATED LOCATION TWO IDENTIFICATION	C
X		3233	Related place/location two identification	C an..25
X		1131	Code list qualifier	C an..3
X		3055	Code list responsible agency, coded	C an..3
X		3232	Related place/location two	C an..70
X	5479		RELATION, CODED	C an..3

**Segment:** **RFF** Reference (CNI.GID.DGS.RFF)  
**Position:** 0480  
**Group:** Segment Group 12 (Dangerous Goods)  
**Level:** 4  
**Usage:** Conditional  
**Max Use:** 9  
**Purpose:** To specify a reference.  
**Comments:**  
**Notes:**

## Data Element Summary

	<u>Data Element</u>	<u>Component Element</u>	<u>Name</u>	<u>UN/EDIFACT</u>
M	C506		REFERENCE	M
M		1153	Reference qualifier <i>ALF</i>	M an..3 <i>An approval concerning an exception on the existing dangerous goods regulation.</i>
R		1154	Reference number <i>Radio Call Sign</i>	C an..35
X		1156	Line number	C an..6
X		4000	Reference version number	C an..35
X		1060	Revision number	C an..6

**Segment:** **SGP** Split Goods Placement (CNI.GID.DGS.SGP)  
**Position:** 0500 (Trigger Segment)  
**Group:** Segment Group 13 (Split Goods Placement)      Dependent Max Use = 99  
**Level:** 4  
**Usage:** Mandatory  
**Max Use:** 1  
**Purpose:** A segment to identify the equipment (such as container number, barge identification, trailer identification) in which the dangerous goods is placed and the number of packages in that equipment.

**Comments:**  
**Notes:** *Sample segment :*  
*SGP+TTNU3344760+320'*

## Data Element Summary

	<u>Data Element</u>	<u>Component Element</u>	<u>Name</u>	<u>UN/EDIFACT</u>
M	C237		EQUIPMENT IDENTIFICATION	M
R		8260	Equipment identification number <i>Containernumber</i>	C an..17
X		1131	Code list qualifier	C an..3
X		3055	Code list responsible agency, coded	C an..3
X		3207	Country, coded	C an..3
O	7224		NUMBER OF PACKAGES <i>Number of packages in the container</i>	C n..8

**Segment:** **LOC** Place/Location Identification (CNI.GID.DGS.SGP.LOC)  
**Position:** 0510  
**Group:** Segment Group 13 (Split Goods Placement)  
**Level:** 5  
**Usage:** Required  
**Max Use:** 1  
**Purpose:** A segment to indicate the cell location on board of the means of transport, for each equipment in which dangerous cargo is stored.

**Comments:**

**Notes:** *Sample segment :*  
*LOC+147+0120782'*

**Data Element Summary**

	<u>Data Element</u>	<u>Component Element</u>	<u>Name</u>	<u>UN/EDIFACT</u>
M	3227		PLACE/LOCATION QUALIFIER <i>147 Stowage cell</i>	M an..3
R	C517		LOCATION IDENTIFICATION	C
R		3225	Place/location identification <i>Stow position on board the vessel in ISO format : BBBRRTT</i>	C an..25
X		1131	Code list qualifier	C an..3
X		3055	Code list responsible agency, coded	C an..3
X		3224	Place/location	C an..70
O	C519		RELATED LOCATION ONE IDENTIFICATION	C
O		3223	Related place/location one identification	C an..25
X		1131	Code list qualifier	C an..3
X		3055	Code list responsible agency, coded	C an..3
O		3222	Related place/location one	C an..70
X	C553		RELATED LOCATION TWO IDENTIFICATION	C
X		3233	Related place/location two identification	C an..25
X		1131	Code list qualifier	C an..3
X		3055	Code list responsible agency, coded	C an..3
X		3232	Related place/location two	C an..70
X	5479		RELATION, CODED	C an..3

**Segment:** **MEA** Measurements (CNI.GID.DGS.SGP.MEA)  
**Position:** 0520  
**Group:** Segment Group 13 (Split Goods Placement)  
**Level:** 5  
**Usage:** Conditional  
**Max Use:** 4  
**Purpose:** To specify physical measurements, including dimension tolerances, weights and counts.  
**Comments:**  
**Notes:** *Sample segment :*  
*MEA+AAE+G+KGM:8302'*

## Data Element Summary

	Data Element	Component Element	Name	UN/EDIFACT
M	6311		MEASUREMENT PURPOSE QUALIFIER <i>AAE Measurement</i>	M an..3
R	C502		MEASUREMENT DETAILS	C
R		6313	Property measured, coded <i>AAL Net weight</i> <i>G Gross weight</i>	C an..3
X		6321	Measurement significance, coded	C an..3
X		6155	Measurement attribute identification	C an..17
X		6154	Measurement attribute	C an..70
R	C174		VALUE/RANGE	C
M		6411	Measure unit qualifier <i>KGM Kilogram</i>	M an..3
R		6314	Measurement value <i>Net/gross/net explosive weight</i>	C an..18
X		6162	Range minimum	C n..18
X		6152	Range maximum	C n..18
X		6432	Significant digits	C n..2
X	7383		SURFACE/LAYER INDICATOR, CODED	C an..3

**Segment:** **UNT** Message Trailer  
**Position:** 0530  
**Group:**  
**Level:** 0  
**Usage:** Mandatory  
**Max Use:** 1  
**Purpose:** A service segment ending a message, giving the total number of segments in the message and the control reference number of the message.

**Comments:**

**Notes:** *Sample segment :*  
*UNT+130+6700001'*

**Data Element Summary**

	<u>Data Element</u>	<u>Component</u>		<u>UN/EDIFACT</u>
		<u>Element</u>	<u>Name</u>	
M	0074		NUMBER OF SEGMENTS IN A MESSAGE <i>Total number of segments in the message</i>	M n..6
M	0062		MESSAGE REFERENCE NUMBER <i>Message reference identical to e0062 in UNH segment</i>	M an..14

## Revision history

Date issued	Version no.	Changes	Changed by
February 16, 2005	A	First release	SMA – ThoDah/AF
March 29, 2005	B	Second release, Port visit ID in TDT.RFF Flow diagram, modified footers, no S009.0057 in UNH	SMA – ThoDah/AF
April 5, 2005	PC1	Contact person, phone and fax required. TDT.LOC required for using port of call as contact person's location code. CNI_C503.1004 changed from Optional to Dependent, i.e. used by SMA.	SMA – ThoDah/AF